



922D

922D

2.55

The Hydrema 922D is the obvious choice for driving on soft terrain and in areas that demand the lowest possible ground pressure. Hydrema's three-axle dump truck, with its unique articulated pivot joint and bogies with a wide steering angle, offers superior tractive power and the market's lowest unladen weight and performance/weight ratio, resulting in extremely low fuel consumption. For road use, choose the 2.55 version. Hydrema's D series sets the standard in the 20t class.

Low unladen weight and superb tractive power

The 922D has an exceptionally low unladen weight and the best performance/weight ratio ever. It is designed as an articulated three-axle dump truck. The articulated chassis has pendulum bar and double hydraulic stabilisers in the pivot joint. These features ensure great stability during operation and when performing tipping operations, even when the dump truck is at maximum oscillating angle.

The 922D breaks with traditional design principles for dump trucks in its class in a number of areas. All components are optimised precisely for the 922D, a major contributory factor to the low unladen weight. Because the Hydrema 922D is specially designed for driving on very soft surfaces with extra wide tyres (800 mm), it is possible to work both early and late in the season. The narrow 922D 2.55 version* can be registered for use on public roads and is available in 30 km/h and 50 km/h versions.

* with EM 20.5R25 tyres.

Transmission

The tractive power on the six wheels stems from the automatic transmission with six forward and three reverse gears. The ultra-modern ZF transmission is equipped with 100% 'lock-up'

in all gears, giving direct drive which bypasses the converter, and thus minimal energy loss. The specially optimised software ensures the best possible connection between the engine and the transmission in any condition.

To equalise the speed differential between the dump truck's front and rear axles and ensure optimal accessibility, the transmission is equipped with a centre differential with 100% differential lock. The transmission's shifting mechanism is electronically controlled via a joystick. You can choose between a fully automatic or manual tip-tronic gearshift. The advanced ergopower shift system ensures a very smooth gearshift, prevents wheel spin and gives the best possible traction in difficult conditions. Operation is quick and effective, as the same joystick is used for both the gear system and the tipping function.

Powerful hydraulic system

The hydraulic system in the 922D consists of no fewer than four hydraulic pumps. This solution was chosen to ensure that the machine's functions operate independently with the least possible energy loss. Thus two pumps with constant output function as: brakes, stabilisers in the centre pivot, differential lock, front-axle suspension and tipping. The two other pumps with variable output take care of the pivot steering function and the emergency steering function. The separate pumps ensure completely independent control of the steering and tipping function, which means that the vehicle can be positioned as the tipping is started. On other models the steering is often restricted when the tipping function is used – not so with the Hydrema 922D. The variable pump for the steering supplies a very large quantity of oil even at low engine revs, which ensures that the steering never feels sluggish. An energy-efficient and very comfortable solution.

Cab

Hydrema's new D series cab gives the operator more room and improved visibility. Its high, central location and the steeply inclined, narrow hood gives the operator what is probably the best all-round visibility on the market: at the front of the vehicle, beside the engine and adjacent to the front wheels. The cab has a soft-touch interior and all the instrumentation is placed according to careful studies of the operator's everyday working situation and optimal working position. The steering wheel, seat and arm rests are adjustable to suit the individual operator.

The cab is equipped as standard with a robust climate-control system, which, along with the visco-elastic cab suspension points and the air-sprung seat, gives the operator the best possible working conditions. The operator also has a refrigerated storage space.

Safety is optimal, the cab being fitted with easily accessible mount and dismount steps on both sides and entry and exit lighting when dark. Broad, electrically adjustable heated mirrors give the operator good rear visibility. The cab also has 12V and 24V electrical sockets for the operator's own equipment.



Electronic suspension and level control – and 'genuine' bogie axles

The front axle is fitted with a new electronically controlled suspension and level control which provides great operator comfort at all speeds. The level control is separate on each side of the axle, which keeps the machine on a level when rounding corners. The front chassis can also be raised electronically by approximately 50 mm, making progress easier in very soft terrain. The rear axle is a heavy-duty bogie axle with reduction gear. This is a very simple, maintenance-free and hard-wearing construction.

Hydrema has fitted the 922D with a 'genuine' bogie axle because this construction has been shown to have better off-road performance than normal rigid axles. On the bogie axle each wheel has much greater freedom of movement than two single axles and thus better contact with the surface. Ground pressure is minimised as all six wheels stay in contact with the terrain. In addition, the bogie axles' individual movements guarantee greater operator comfort.

Dump truck body

The body is made of high-tensile Hardox steel. The flat, sloping rear edge and a high tipping angle of 72° ensure effective tipping – material is discharged from the body quickly and easily. The powerful double-acting tipping cylinders have maximum protection on the underside of the body. The tipping hydraulics with servo automatically increases the engine revs when the tipping control lever is activated, thus achieving very fast tipping cycle times of just 7.5 sec. (up) and 5.5 sec. (down). The tipping cylinders are fitted with an end brake at each end to ensure that the body is lowered gently onto the chassis and the tipping speed is reduced just before the maximum tipping angle is reached. The auto body return function causes the body to descend automatically when the operator tips the joystick forward and lets go.



Computer-controlled instrument display

The Hydrema 922D has a Windows-based instrument display with a 6.4" screen. The display gives the operator all the necessary information during operation, including text warnings if an abnormal operational situation arises. The computer is installed with data collection for service and instructions on daily maintenance for the operator.

Engine

In difficult terrain a dump truck needs lots of engine power and tractive power. Therefore from the beginning of the design process focus was put on achieving optimal off-road terrain qualities and extremely high traction. The engine is a six-cylinder Cummins turbo with intercooler, 24-valve technology, power boost function, and a fully electronic fuel injection system. The modern engine technology and variable speed fan provide very low fuel consumption and low noise levels.

Brakes and bogie brake

The completely enclosed, oil-immersed operational brakes and handbrakes ensure safe braking, optimal cooling, and durability even in the toughest conditions. The brake system consists of two independent circuits and the handbrake is a spring-activated fail-safe brake. The vehicle has a standard, fully automatic bogie brake which works without the operator's intervention and ensures a very stable vehicle even during very steep downhill driving. The bogie brake is a combination of the engine brake and a newly developed hydraulic bogie brake which together provide superior braking ability.

TECHNICAL DATA:

Chassis:

Articulated chassis with pendulum bar and double hydraulic stabilizers in the centre pivot. The two stabilizers provide a high degree of stability both when driving and when carrying out dumping operations. The chassis is fabricated in high tensile steel in order to obtain the highest possible strength and the lowest possible unladen weight.

Oscillation: +/- 12°

Axles:

Front: rigid axle with electronically controlled suspension and level control. Individual level control on each side enables the vehicle to remain level when driving fast round corners. The front axle has a differential lock with 75% locking action. Rear: heavy-duty bogie axle with reduction gear at the differential and slow-moving gear in the bogie boxes. Simple and maintenance-free design.

Engine:

Cummins QSB 24 valve, 6.7 litre 6 cyl. stage 3a, with turbo and intercooler. 194 kW/264 hp at 2200 rpm. Power bulge: 201 kW/274 hp at 2000 rpm. Max. torque 990 Nm at 1300-1500 rpm. The engine is equipped with 24 valves and a fully electronically controlled common rail injection. The engine fan runs at variable revs according to cooling requirements. Latest engine technology which meets EEC stage 3a requirements for exhaust emission.

Transmission:

ZF ERGOPOWER 6 WG 210 automatic transmission with 6 forward gears and 3 reverse gears. The transmission is equipped with 100% "lock-up" in all gears, which electronically locks the connection between the engine and the transmission, and gives direct drive which bypasses the converter. A centre differential is located in the transmission's output shaft in order to equalise the speed differential between the front and rear axle. The centre differential has 100% differential lock. Electronic control of the transmission's shifting mechanism via a joystick (ZF Ergo 2), fully automatic or manual gearshift. Smooth gearshift which prevents wheel slip in difficult conditions. Max. speed: forward: 50 km/h / reverse: 31 km/h - Max. tractive effort: 212 kN.

Steering:

The new servo activated hydrostatic steering results in great comfort, since impacts from the terrain are not transferred through to the steering wheel. Separate variable pump for steering function. Max. steering angle: +/- 38°

Brakes:

Full dual-circuit brake system with oil-immersed disc brakes on all 6 wheels. Fail-Safe parking brake on the front axle. Maintenance-free brakes. The brakes can be activated by a push button before dumping operations are commenced.

Retarder:

Exhaust brake and hydraulic retarder. Automatic controlled exhaust brake via engine. The hydraulic retarder can be engaged manually when needed.

Hydraulic system:

The hydraulic system consists of 4 independent hydraulic pumps: Pump 1: 32 l/min constant flow pump for brake, stabilizer, differential lock and suspension. Pump 2: 150 l/min variable flow pump for pivot steering. Pump 3: 170 l/min constant flow pump for tipping function. Pump 4: 64 l/min variable flow pump for emergency steering.

Electrical system:

Standard 24V el. system with 70 Amp. alternator.

Tyres:

Standard:

922D: 600/60-30.5 - Ground press., load.: 117 kPa. 922D-2.55: EM 20.5 R25 - Gr. press., load.: 132 kPa

Option:

922D: EM 20.5 R25 - Ground press., load.: 132 kPa. 922D: 800/45-30.5 - Ground press., load.: 82 kPa.

Dumptruck body:

Robot-welded dumptruck body in high tensile Hardox 450 steel without side ribs. The double action tipping cylinders are located under the body for maximum protection. As an option, the dumptruck body can be supplied with exhaust heat and an automatically functioning Tail Gate.

DIMENSIONS:

	922D	922D 2.55	
Total weight *	35,800 kg	36,600 kg	
Unladen weight *	15,800 kg	16,600 kg	
Load capacity	20,000 kg	20,000 kg	
Axle weights, front (unladen)	8,000 kg	8,300 kg	
Axle weights, centre (bogie)	3,900 kg	4,150 kg	
Axle weights, rear (bogie)	3,900 kg	4,150 kg	
Axle weights, front (loaded)	10,800 kg	11,100 kg	
Axle weights, centre (bogie)	12,500 kg	12,750 kg	
Axle weights, front (bogie)	12,500 kg	12,750 kg	
B Total width:	Tyres: (600/60-30.5) Tyres: (EM 20.5R-25) Tyres: (800/45-30.5)	2,870 mm 2,920 mm 3,240 mm	- 2,550 -
C Ground clearance		480 mm	480 mm
D Width, body		2,750 mm	2,550 mm
E Max. height		3,390 mm	3,390 mm
Transport height		3,440 mm	3,440 mm
F Loading height		2,590 mm	2,590 mm
G Height raised body		6,290 mm	6,290 mm
H Tipping clearance		820 mm	820 mm
I Overhang, rear		1,410 mm	1,410 mm
J Wheel base, bogie		1,636 mm	1,636 mm
K Length		9,130 mm	9,130 mm
L Approach angle, front		25 °	25 °
M Approach angle, rear		67 °	67 °
N Tipping angle		72 °	72 °
O Wheel base		3,708 mm	3,708 mm
R Overhang, front		2,380 mm	2,380 mm
Body capacity, level		8.9 m³	8.75 m³
Body capacity, heaped		12.0 m³	12.0 m³
Tipping time, raise		7.5 sec.	7.5 sec.
Tipping time, lower		5.5 sec.	5.5 sec.
Turning radius, outer *		8,511 mm	8,165 mm
Fuel tank		300 l	300 l
Hydraulic tank		200 l	200 l

* 922D: 600/60-30.5 tyres
922D-2.55: 20.5-R25 tyres

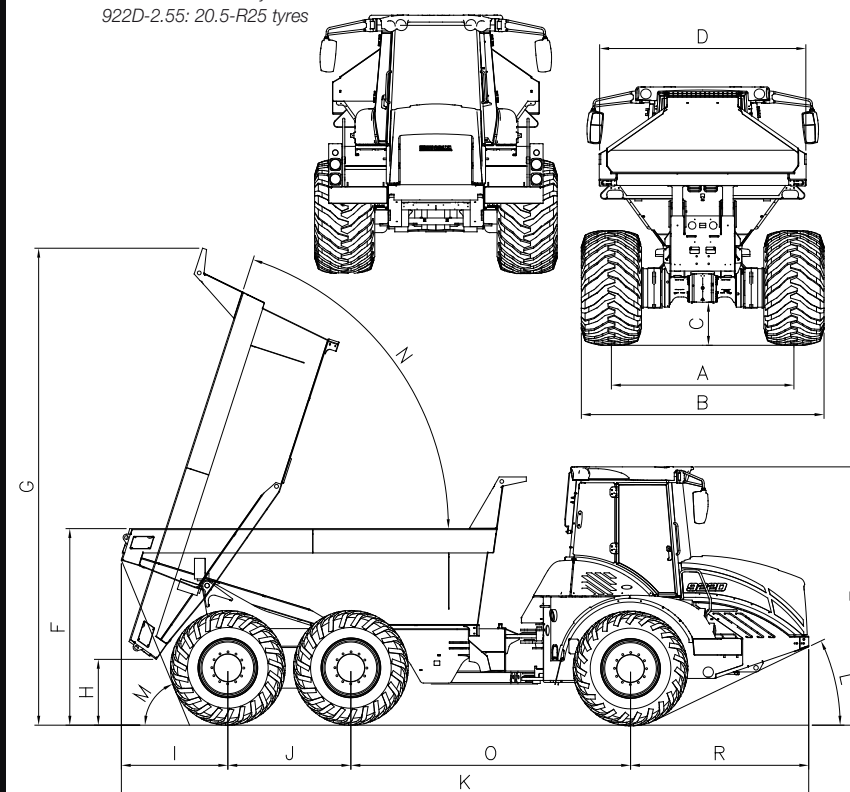



922D
922D
2.55

STANDARD EQUIPMENT:

Safety...

- ◆ Large heated side-view mirrors with swivel joint
- ◆ Rear lights integrated in dump body
- ◆ 8+2 working lights
- ◆ Non-slip steps for cab access and egress
- ◆ Acoustic reversing alarm
- ◆ Maintenance-free service and parking brake
- ◆ Rear view camera
- ◆ Hydraulic retarder

Cab/comfort....

- ◆ Climate Control system
- ◆ Air-suspended seat
- ◆ Visko-elastic cab suspension
- ◆ Bonnet with electric opening
- ◆ Front axle with suspension with automatic level control
- ◆ Multifunction joystick in right armrest
- ◆ Air filter and exhaust system located under hood
- ◆ 4 halogen front lights
- ◆ Computer-controlled instrument panel
- ◆ Two doors with easy access

Chassis...

- ◆ 12° oscillation in centre pivot
- ◆ Articulated with two hydraulic stabilisers in the pivot
- ◆ Weight transfer
- ◆ Hydraulic lines hidden/protected in centre pivot just above cardan shaft



OPTIONAL EQUIPMENT:

- ◆ Body exhaust heating kit
- ◆ Tail gate
- ◆ Rear lights protection
- ◆ Engine heater (220 v)
- ◆ Tyres:
800/45x30.5
20.5 R25 EM
- ◆ Electric fuel pump
- ◆ Automatic central lubrication system
- ◆ Xenon working lights
- ◆ Diesel heating - 9 kW

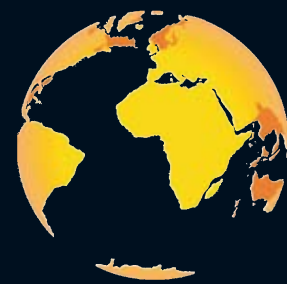

A/S HYDREMA EXPORT
Gl. Kirkevej 16
DK-9530 Stovring
Phone +45 98 37 13 33
Fax +45 98 37 19 96
e-mail: hydrema@hydrema.com



www.hydrema.com



922D
922D
2.55



HYDREMA

Subject to changes. Text and photos may describe/show optional equipment - 08/2010