



906D 908D

With the D-series we have created a new generation of the unique loader/excavators, machines that can only be compared with specialized loaders and mobile excavators. Hydrema signifies a number of special characteristics, top quality throughout and finish down to the smallest detail. The characteristics make these machines the most efficient and flexible for customers demanding comfort and productivity.

Centre pivot and roadholding qualities

The key to the excellent on and off road performance of the 906D/908D lies in the articulated pivot steer chassis. The centre pivot and hydraulic stabilisers keep the machine stable and safe by automatically transferring the weight where it is needed. The chassis ensures that all wheels constantly track to reduce ground contact and the centrally placed pivot increases manoeuvrability with a low turning radius and better positioning characteristics.

The addition of a new cruise control makes for more comfortable road usage.

Loader

The Hydrema 906D and 908D are full articulated loading shovels. Constructed from high tensile steel and with a high torque engine and automatic flexible transmission the D series are outstanding loaders. Equipped with auto self levelling, Z-kinematics and a return to dig function the shovel is easy to fill and offers exceptional break out force.

The load stabilizer and upgraded ESD servo control system ensures smooth efficient operation of the shovel while the double command feature gives the operator all the flexibility needed for an efficient day's work.

The D series loaders have the same performance, breakout force and lifting capacity as a typical 1.3 m³ loader but with the benefit of an additional rear mounted excavator.

Excavator

The boom and dipper are constructed as closed profiles in high tensile steel that provides maximum strength and stiffness. Heavy-duty sleeve bearings at all the joints featuring Hydrema's wellknown double sealing system to ensure long life and low operating costs.

The curved design enables easy loading over the side of a truck, and gives greater flexibility when working close to the machine. The excavator can also be fitted with a telescopic arm, which increases the reach and excavating depth by 1.2 m. This also means longer working intervals from the same position.

The excavator's mode control makes it possible for the operator to adapt the speed of the hydraulic to the task in question. E.g. very low speed ensures maximum safety at lifting tasks.

Optimum operator comfort

The D series is fitted with a newly designed spacious cab which improves visibility and comfort. The operator now has an electrical steering column which automatically tilts when the operator goes from a driving to a digging position and back again. The sound level in the cab has been significantly reduced to only 69 dB(A) which is the lowest to be found on any loader/excavator.

After studying the working situation and posture of the operator we have produced our most modern cab to date. All the instrumentation is ergonomically placed, the seat and armrests are fully adjustable and the cab is lined with a new soft touch interior.

Visibility has been improved by increasing the glazed area and a new a/c system is incorporated as standard with 10 air nozzles placed throughout the cab. Overall vibration has been reduced by mounting liquid filled engine suspension points and a cab suspension system. The cab is also fitted with automatic entry and exit lighting for safer night time operation.

User friendly computer

The Hydrema 906D/908D have a Windows based instrument display which provides the operator with a wealth of information via a 6.4" flat-screen PC monitor. The computer has data collection, rental menu and diagnostic tools installed.

The menu is very user-friendly, even for inexperienced operators and it is possible to update the software and download data from the machine via a USB socket.



New joysticks

The all new armrests with integrated joysticks have four proportional functions built-in which make operation of tools absolutely precise and unique. This is especially useful when using hydraulic attachments such as a »rototilt« where precise control is of the utmost importance to productivity. The armrests are also multi-adjustable so they can be adapted to suit the individual operator.

Dynamic design

A lot of time and effort has gone into the design of the 906D/908D to keep them ahead of the market in terms of quality and function. Industrial designers have been employed to attend to every detail from the eight working lights to the built in tool boxes and soft touch interior. The operator has a superb working environment with

easy to understand controls, heated seating, electrical adjustable side mirrors and the best performance available on the market. Companies that invest in a Hydrema send a message to their customers that they use top quality equipment.



DIMENSIONS:

		906D	906D Telescopic	908D	908D Telescopic	908D Side-ang	908D Telesc. + side-ang.
Total weight	kg	8,200	8,350	8,100	8,250	8,600	8,750
Width over std. tyres	mm	2,250	2,250	2,250	2,250	2,250	2,250
Track std. tyres	mm	1,750	1,750	1,750	1,750	1,750	1,750
Wheel base	mm	2,415	2,415	2,415	2,415	2,415	2,415
Turning radius - outer shovel corner	m	5.2	5.2	5.2	5.2	5.2	5.2

EXCAVATOR:

Bucket size, max. (ISO 7451)	m ³	0.35	0.35	0.43	0.43	0.43	0.43
Slew angle	°	280	280	200	200	200+2x25	200+2x25
A Approach height, max	mm	5,980	6,050/6,880	6,060	6,130/6,930	6,060	6,130/6,930
B Lifting height - level base of bucket	mm	4,120	4,190/5,020	4,210	4,280/5,090	4,210	4,380/5,090
C Bucket clearance	mm	1,170	1,170	1,300	1,300	1,300	1,300
D Excavating depth	mm	4,860	4,860/6,060	5,380	5,390/6,590	5,380	5,390/6,590
E Reach	mm	6,200	6,230/7,370	6,500	6,530/7,670	6,500	6,530/7,670
F Distance - centre pivot to rear axle	mm	1,485	1,485	1,050	1,050	1,050	1,050
G Bucket rotation	°	190	190	190	190	190	190
H Ground clearance	mm	400	400	400	400	400	400
I Clearance height	mm	2,900	2,900	2,900	2,900	2,900	2,900
J Transport height	mm	3,970	3,970	4,000	4,000	4,000	4,000
K Angle of departure	°	21	21	24	24	24	24
Sideshift	mm	1,400	1,400	-	-	-	-
Breakout force excav. cyl. - max. bucket ISO 6015	kN	36	36	35	35	35	35
Breakout force bucket cyl. - max. bucket ISO 6015	kN	53	53	53	53	53	53
Slewing torque	kNm	-	-	22.6	22.6	22.6	22.6
Lifting capacity - max. reach excl. appliances	kg	1,400	1,200/900	1,650	1,450/1,110	1,650	1,400/1,160
Stabilizers - supporting width	mm	3,330	3,330	3,880	3,880	3,880	3,880
Stabilizers - max. alignment angle	°	11.5	11.5	11.5	11.5	11.5	11.5

LOADER:

Shovel size max.	m ³	1.3	1.3	1.3	1.3	1.3	1.3
L Lifting height - horizontal shovel	mm	3,410	3,410	3,410	3,410	3,410	3,410
M Clearance height - tipped shovel	mm	2,840	2,840	2,840	2,840	2,840	2,840
N Excavating depth - horizontal shovel	mm	140	140	140	140	140	140
O Reach - tipped shovel	mm	690	690	690	690	690	690
P Reach - at ground level	mm	1,500	1,500	1,500	1,500	1,500	1,500
Q Emptying angle - max. height	°	45	45	45	45	45	45
R Back-tip angle - ground level	°	45	45	45	45	45	45
S Dumping angle - ground level	°	100	100	100	100	100	100
T Height, shovel pivot	mm	3,645	3,645	3,645	3,645	3,645	3,645
Lifting capacity - max. height excl. appliances	kg	4,000	4,000	4,000	4,000	4,000	4,000
Breakout force - 1.3 m ³ shovel, ISO 8313	kN	66.3	66.3	66.3	66.3	66.3	66.3
Width standard shovel	mm	2,280	2,280	2,280	2,280	2,280	2,280

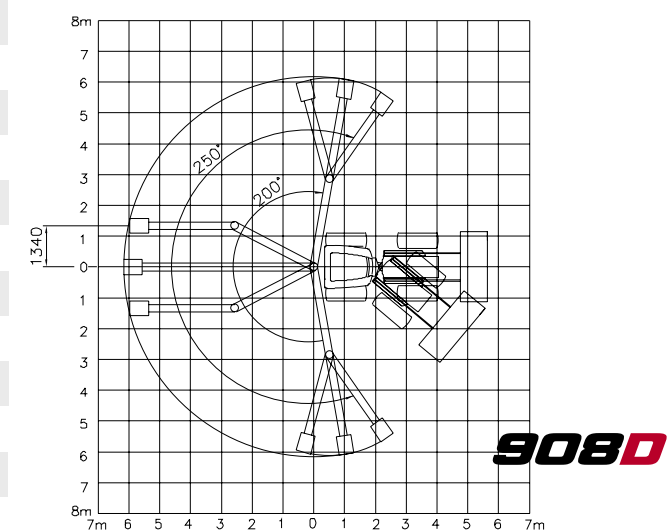
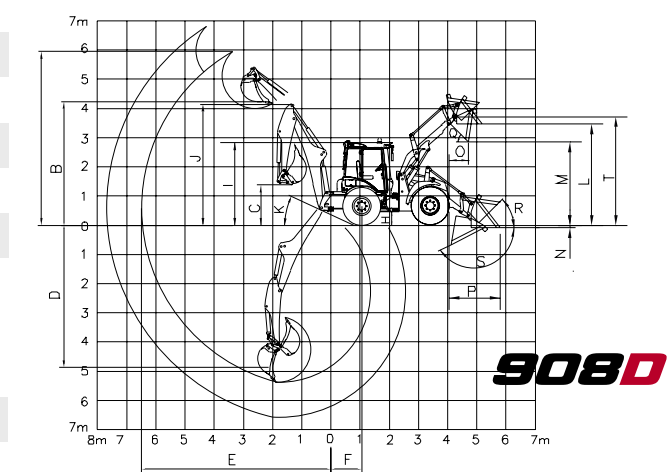
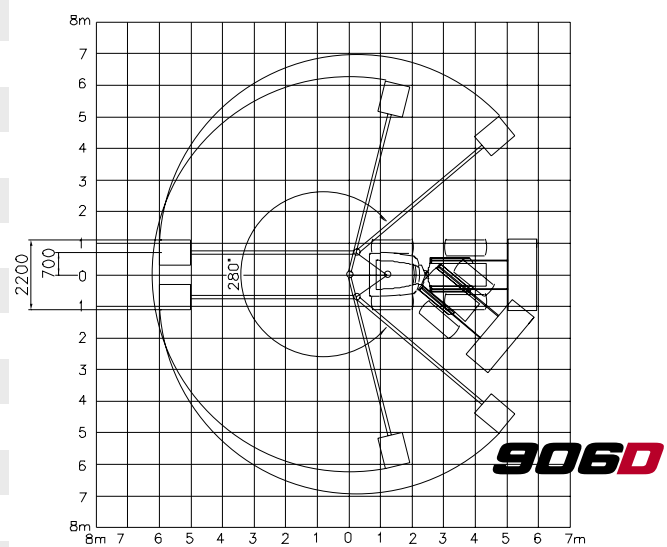
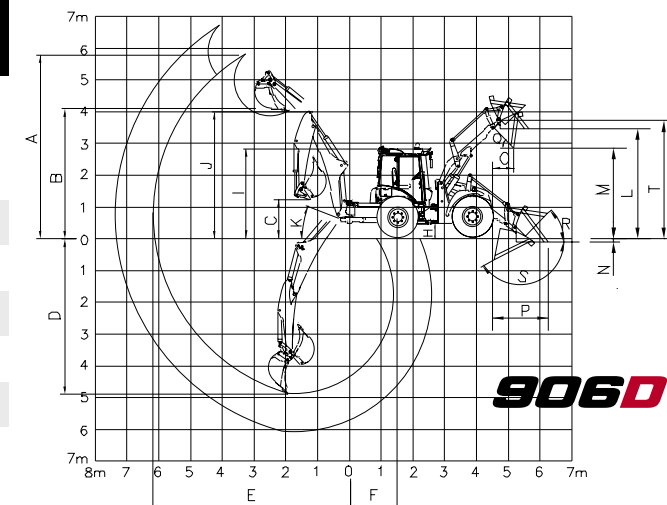

TECHNICAL DATA:

Chassis:

Articulated chassis in heavy-duty robotically welded construction with fixed axles. Centre pivot with pendulum bar and hydraulic stabilisers with the option of hydraulic locking of the oscillating movement. The centre pivot is fitted with large spherical pivot bearings. Max oscillation ± 11°

Steering:

Hydrostatic steering with »Load Sensing« hydraulics and two double-acting cylinders. Priority valve and integrated emergency steering. Steering cylinders with end damping. Max. steering angle..... ± 35°

Axles:

Fixed, rigid axles with planetary hub reduction. Automatic limited slip differential lock on front axle. 100% electro-hydraulic differential lock on rear axle (ESD). Separate oil chambers for differentials and hubs.

Transmission:

Clark fully-automatic electronically controlled transmission. Number of gears: 6 forward/3 reverse. Double »kickdown«. Torque converter with torque increase and free-wheel. Permanent 4-wheel drive.

Brakes:

Hydraulic twin-circuit servosystem with oil-immersed disc brakes on all wheels. Self-adjusting, maintenance-free. Maintenance-free »FAIL SAFE« parking brake with electro-hydraulic activation of the wet discbrakes on the front axle.

Hydraulic system:

Compensated »Load Sensing« system with 150 l/min at 2000 rpm. Hydraulic pressure: 225 bar. Variable displacement pump and closed centre control valves with pressure-compensated flow regulation on the primary functions and function for extra outlet. The ESD models have double command, electronic mode control and electric servo operation of all hydraulic functions incl. the stabilizers.

Engine:

Perkins 1104D-E44T stage 3a engine. 4.4 l turbo-diesel engine with direct injection. 75 kW/102 hp at 2200 rpm. Max. torque: 420 Nm at 1400 rpm. Latest engine technology that meets EEC stage 3a requirements for exhaust emission. 130 l fuel tank integrated into the front chassis.

Noise level:

LwA: (exterior) 102 dB(A) 2000/14/EC
LpA: (cab) 69 dB(A) ISO 6396

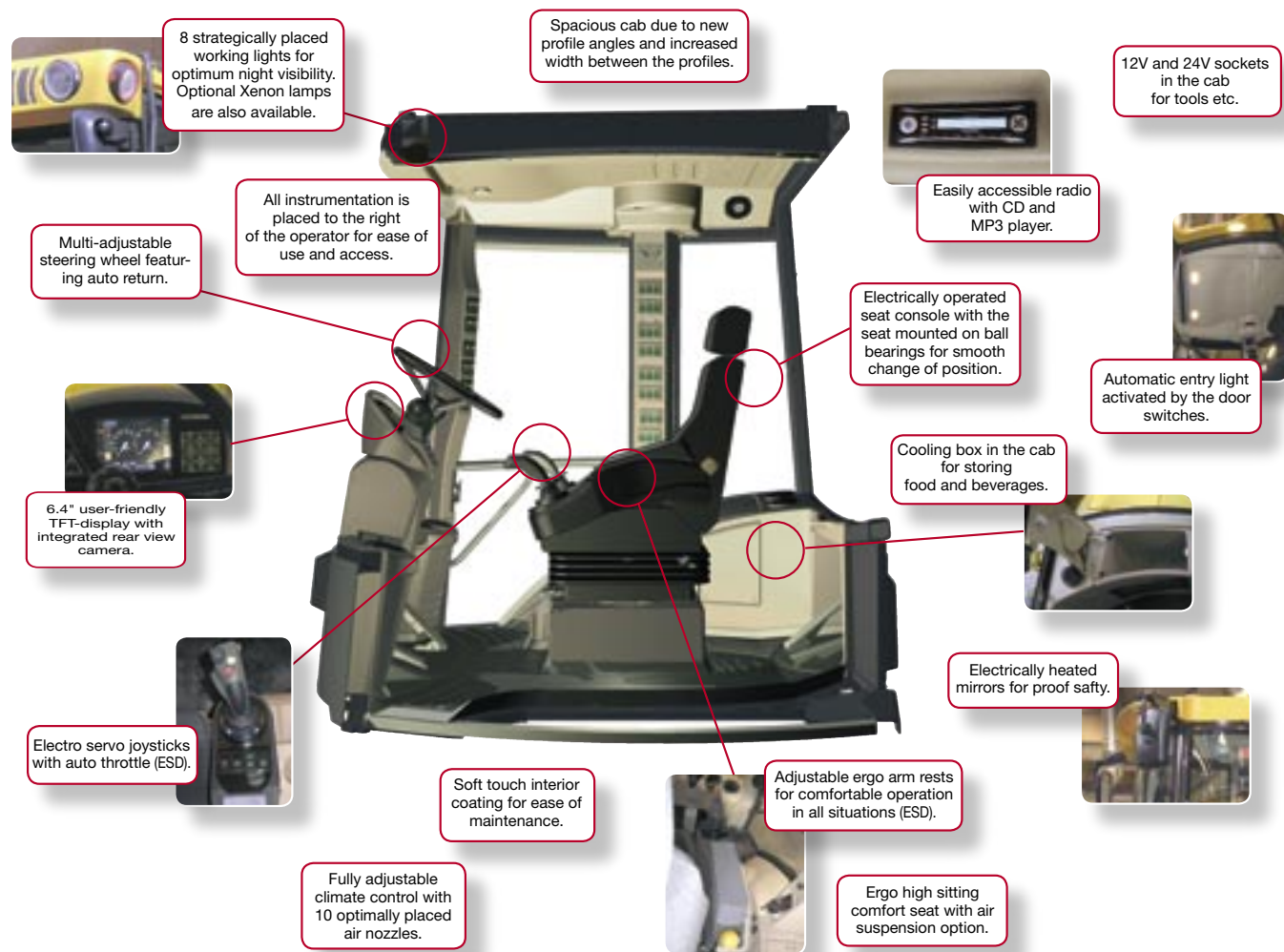

906D
908D

STANDARD EQUIPMENT:

- ◆ 500/70-24 Michelin tyres
- ◆ Friction differential lock in front
- ◆ 100% differential lock rear (ESD)
- ◆ Oscillating lock (ESD)
- ◆ Excavating brake (ESD)
- ◆ Load stabilizer (ESD)
- ◆ Hydraulic pipework on loader (ESD)
- ◆ Hydraulic quick hitch on loader (ESD)/excavator
- ◆ Pipework on excavator (ESD)
- ◆ Climate control system, automatic
- ◆ Headrest
- ◆ Rotating beacon light
- ◆ Warning triangle
- ◆ Radio with CD and MP3
- ◆ Automatic return-to-dig on loader (ESD)
- ◆ Belly plate rear (908D)
- ◆ Electrically heated side mirrors
- ◆ Seat heating
- ◆ Cruise control
- ◆ Automatic driving lights
- ◆ 8 Mega Beam work lights
- ◆ Electric operated seat console and steering wheel adjustment
- ◆ Automatic throttle control
- ◆ Cooling box
- ◆ 12V/24V plug in the cab
- ◆ Side mirrors for double command (ESD)
- ◆ Intermittent wind shield wipers front/rear
- ◆ Solar blind front
- ◆ Portable lamp
- ◆ Red night illumination in cab
- ◆ Electric adjustable mirrors in front
- ◆ Rear view mirror in cab

OPTIONAL EQUIPMENT:

- ◆ Hydraulic quick hitch for loader - BM
- ◆ Shovel protection loader
- ◆ Telescopic arm excavator
- ◆ Short dipper for rotortilt
- ◆ Extra pipework
- ◆ Rubber plates for stabilizer
- ◆ Hydraulic quick hitch excavator
- ◆ Engine heater
- ◆ Bio hydraulic oil
- ◆ Optional tyres:
600x55-26.5 TWIN - 17.5Rx25 EM - Nokia 520/65x24
- ◆ Belly plate in front
- ◆ Mudguards on front fenders
- ◆ Air-suspended seat
- ◆ Remote control for radio
- ◆ Xenon work lights
- ◆ Work lights on dipper
- ◆ Rear view camera
- ◆ Extra rotating beacon light
- ◆ Steering wheel knob
- ◆ Electric adjustable mirrors in front
- ◆ Solar blind rear



A/S HYDREMA DANMARK

Gl. Kirkevej 16
DK-9530 Støvring
Tel.: +45 98 37 13 33
Fax: +45 98 37 19 96
e-mail: hydrema@hydrema.com



www.hydrema.com



906D
908D



HYDREMA